

XR8 SPOT



User's Manual Rel 1.2 **GB**

D.T.S. Illuminazione srl - ITALY
<http://www.dts-lighting.it>



The Lighting Company

Made in Italy

Le informazioni contenute in questo documento sono state attentamente redatte e controllate. Tuttavia non è assunta alcuna responsabilità per eventuali inesattezze. Tutti i diritti sono riservati e questo documento non può essere copiato, fotocopiato, riprodotto per intero o in parte senza previo consenso scritto della D.T.S.

D.T.S. si riserva il diritto di apportare senza preavviso cambiamenti e modifiche estetiche, funzionali o di design a ciascun proprio prodotto. D.T.S. non assume alcuna responsabilità sull'uso o sull'applicazione dei prodotti o dei circuiti descritti.

The information contained in this publication has been carefully prepared and checked. However, no responsibility will be taken for any errors. All rights are reserved and this document cannot be copied, photocopied or reproduced, in part or completely, without prior written consent from D.T.S. D.T.S. reserves the right to make any aesthetic, functional or design modifications to any of its products without prior notice. D.T.S. assumes no responsibility for the use or application of the products or circuits described herein.

Les informations contenues dans le présent manuel ont été rédigées et contrôlées avec le plus grand soin. Nous déclinons toutefois toute responsabilité en cas d'éventuelles inexactitudes. Tous droits réservés. Ce document ne peut être copié, photocopié ou reproduit, dans sa totalité ou partiellement, sans le consentement préalable de D.T.S.

D.T.S. se réserve le droit d'apporter toutes modifications et améliorations esthétiques, fonctionnelles ou de design, sans préavis, à chacun de ses produits. D.T.S. décline toute responsabilité sur l'utilisation ou sur l'application des produits ou des circuits décrits.

Las informaciones contenidas en este documento han sido cuidadosamente redactadas y controladas. Con todo, no se asume ninguna responsabilidad por eventuales inexactitudes. Todos los derechos han sido reservados y este documento no puede ser copiado, fotocopiado o reproducido, total o parcialmente, sin previa autorización escrita de D.T.S.

D.T.S. se reserva el derecho a aportar sin previo aviso cambios y modificaciones de carácter estético, funcional o de diseño a cada producto suyo. D.T.S. no se asume responsabilidad de ningún tipo sobre la utilización o sobre la aplicación de los productos o de los circuitos descritos.

INDEX:

1- TECHNICAL FEATURES	4
2- IMPORTANT SAFETY INFORMATION	5
2.1 Fire prevention	
2.2 Prevention of electric shock	
2.3 Protection against ultraviolet radiation	
2.4 Safety	
2.5 Level of protection against the penetration of solid and liquid matter	
3- MOUNTING THE LAMP	6
3.1 Lamp alignment	
4- VOLTAGE AND FREQUENCY	7
5- INSTALLATION	7
5.1 Safety cable	
5.2 Protection against liquids	
5.3 Movement	
5.4 Risk of fire	
5.5 Forced ventilation	
5.6 Ambient temperature	
6- MAINS CONNECTION	8
6.1 Protection	
7- DMX SIGNAL CONNECTION	9
7.1 DMX Addresses	
7.2 Selecting the DMX address	
8- DISPLAY FUNCTIONS	11
9- AUTOMATIC MODE	14
9.1 Game P	
9.2 Rec Mode	
10- PAN & TILT SPEED	15
11- FANS SPEED	
12- ERROR MESSAGES	
13- HIDDEN MENU	16
14- OPENING UP THE PROJECTOR HOUSING	17
15- REPLACING GOBOS	
16- PERIODIC CLEANING	18
16.1 Lenses and reflectors	
16.2 Fans and air passages	
17- PERIODIC CONTROLS	
18- DMX PROTOCOLS	19
19- GOBO WHEEL	30
20-COLOUR WHEEL	31
21- MOTORS CONTROL CARD	32
22- PAN & TILT CARD	33
23-CABLES RESEND CARD	
24-DISPLAY CARD	
25- LAMP ON-OFF CONTROL CARD	
26- WIRING DIAGRAM	34

1- TECHNICAL FEATURES

The XR 8 Spot is fitted with a Philips MSR 575/2 discharge lamp (GX9,5 lampholder base), with a colour temperature of 7,200 °K and a luminous flux of 49,000 Lumens.

Duration is 750 hours, with replacement recommended before 1000 hours

Other recommended lamps: Philips 575 MSD (6.000K°-49.000 Lumens-3.000 hours)

The unit incorporates:

Motorized Focus system

Zoom (3 selectable beam aperture angles 11° / 15° / 18° with auto-focus)

Dimmer (emitted light is controlled by progressive and linear dimming).

Shutter (instantaneous shutter opening/closure)

Strobe: mechanical strobe effect (frequency variable from 0.85 flashes/sec to 10 flashes/sec).

Gobo wheel (7 indexable 16 bit gobos + open)

Colour wheel (8 colours + open)

Prism (indexable 3 facet prism rotating in both directions)

Frost Filter

Electronic or magnetic ballast

Pan: 540° in 3.9 seconds (8 or 16 bit) with auto repositioning system

Tilt: 320° in 2.6 seconds (8 or 16 bit) with auto repositioning system

USITT Standard DMX 512 input

20 DMX channels

4 -eight digit- LED display with 4 buttons

2 XLR connectors (In and Out) with 3 and 5 pins selectable by user

Power supply

Electronic ballast:

Universal power supply 90 - 245 V (50/60 Hz)

Electromagnetic ballast:

230 V 50-60 Hz(Standard)

On request: 100 V 50-60 Hz /120 V 60 HZ / 208 V 60 Hz

Power consumption: 750 W.

Remote Lamp on/off via DMX

Operating ambient temperature -10° / 40°

Weight

26 Kg (XR8 SPOT E.B.)

Dimensions (HxDxL)

Projector (670x450x470)

Weight 26 Kg

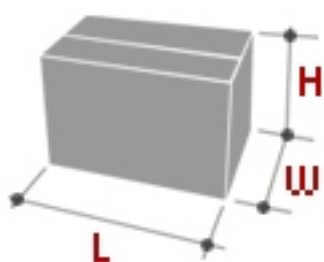

Packing Dimensions
(HxDxL)
800 x 550 x 440 mm
Weight
33.3 Kg



2- IMPORTANT SAFETY INFORMATION

2.1 Fire prevention:

XR8 uses a Philips 575 MSR/2 or MSD

The use of any other alternative lamp is not recommended and will null and void the fixture's warranty.

-Never locate the fixture on any flammable surface.

-Minimum distance from flammable materials: 1 MT.

-Minimum distance from the closest illuminable surface: 2 MT.

-Replace any blown or damaged fuses only with fuses of identical value. Refer to the wiring diagram if there is any doubt.

-Connect the projector to mains power via a thermal magnetic circuit breaker.

2.2 Prevention of electric shock:

-High voltage is present inside the unit. Unplug the unit prior to performing any function which involves touching the inside of the moving head, including lamp replacement.

-The level of technology present in the XR8 requires the assistance of specialised personnel for all servicing. Please refer to an authorised DTS service centre.

-A good earth connection is essential for proper functioning of the projector.

-Never connect the unit without proper earth connection.

-The fixture should be located in places with a good air ventilation.

2.3 Protection against ultraviolet radiation:

-Never turn on the lamp if any of the lenses, filters or ABS covering is damaged. Their respective shielding functions will only operate efficiently if they are in perfect working order.

-Never look directly the lamp when it is on.

2.4 Safety:

-The projector should always be installed with bolts, clamps and other tools that are capable of supporting the weight of the unit.

-Always use a second safety cable to sustain the weight of the unit in case of the failure of the main fixing point.

-The external surface of the unit, at various points, may exceed 70°C. Never handle the unit until at least 10 minutes have elapsed since the lamp was turned off.

-Always replace the lamp if any physical damage is evident.

-Never install the fixture in an enclosed area lacking sufficient air flow. The ambient temperature should not exceed 40°C.

-A hot lamp may explode, so always wait for at least 10 minutes prior to attempting to replace the lamp.

-Always wear suitable hand protection when handling the lamp.

2.5 Level of protection against the penetration of solid and liquid matter:

-The projector is classified as an ordinary appliance and its protection level against the penetration of solid and liquid matter is IP 20.

3- MOUNTING THE LAMPS

Warning: Switch off the unit before replacing the lamp.

Philips 575 MSR/2
Power 575W
Luminous flux 49,000 lm
Colour temperature 7.200°K
Lampbase GX9,5
Rated life 1,000 hours

Philips 575 MSD
Power 575W
Luminous flux 43,000 lm
Colour temperature 6.000°K
Lampbase GX9,5
Rated life 3,000 hours

1) Using a screwdriver, remove the 3 screws A,B, C, (photo 1) which fix the lamp holder.



Photo 1

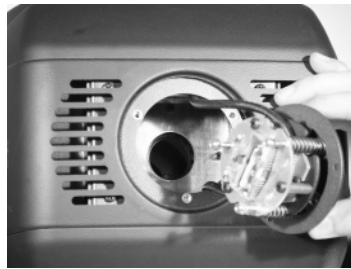

Photo 2

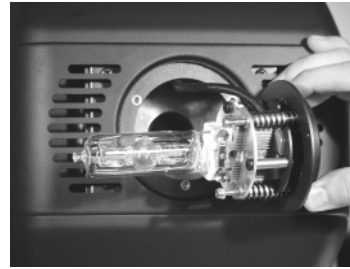

Photo 3



Photo 4

2) Remove the lamp holder assembly (photo2).

3) Insert the lamp (photo 3).

The lamp used on XR 8 is made in quartz glass and should be handled with care. Always follow the instructions supplied in the lamp's packaging. Never touch the glass directly but use the tissue provided in the lamp's packaging. The GX9,5 lamp socket is symmetrical.

DO NOT USE UNDUE FORCE ON THE GLASS. In case of difficulty, read again the instructions and repeat the procedure.

4) Replace the lamp assembly and tighten the screws A,B,C, which were previously removed (photo4).

3.1 Lamp alignment

Attention: we recommend to align the lamp in the optical system to avoid overheating of the dichroic filters and other components inside the unit.



Photo 5

Alignment is carried out using the 3 adjusters X, Y and Z.

During this operation you must have a uniform luminosity all around the projected area.

4- VOLTAGE AND FREQUENCY

The XR8 with electronic ballast can operate at 90-245 VOLT 50 or 60 Hz.

The XR8 with electromagnetic ballast can operate at 230 V 50-60 Hz(Standard)

On request: 100 V 50-60 Hz /120 V 60 HZ / 208 V 60 Hz

5- INSTALLATION

XR8 may be either floor or ceiling mounted.

For floor mounting installations, the XR8 is supplied with four rubber mounting feet on the base.

For ceiling mounted installations, we recommend the use of appropriate clamps to fix the unit to the mounting surface.

The supporting structure from which the unit is hung should be capable of bearing the weight of the unit, as should any clamps used to hang it. The structure should also be sufficiently rigid so as not to move or shake whilst the XR8 is moving.

Four quarter turn fast locks placed on the base of the units, allows by using the two fast lock C clamps provided in the box, to fix the unit in any position.



5.1- Safety cable

We recommend the use of a safety cable or chain connected to the XR8 and to the suspension truss in order to avoid the fixture accidentally falling should the main fixing point fail. Make sure that the iron cable or chain can bear the weight of the entire unit.

You may attach the safety chain to the two holes (A) located on the base of the fixture, as shown in the picture below.

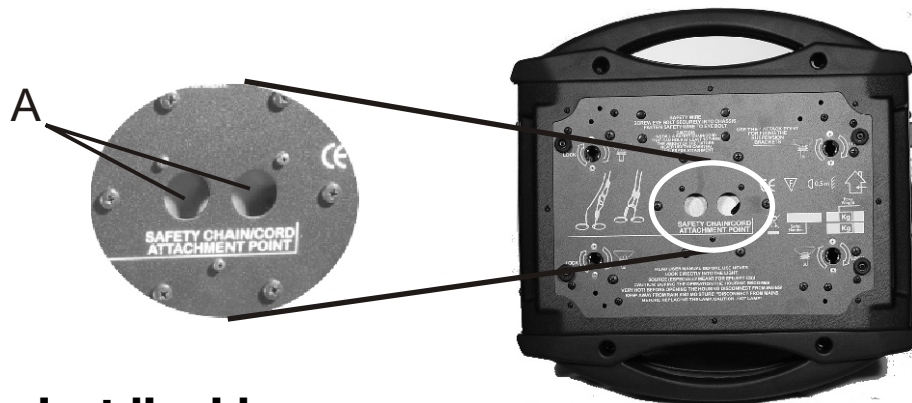

5.2- Protection against liquids

The projector contains electric and electronic components which should under no circumstances come into contact with oil, water or any other liquid. The proper unit functioning would be compromised should this occur.

5.3- Movement

The projector has a maximum movement of 540° for Pan and 270° for Tilt. DO NOT place any obstructions in the path of the projector's movement.

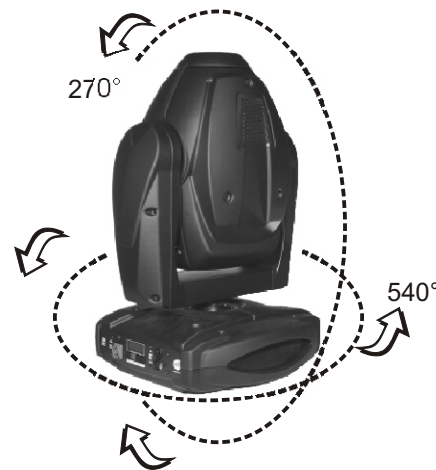

5.4- Risk of fire

Each fixture produces heat and must be installed in a well-ventilated place. The minimum recommended distance from flammable material is 1 MT.

Minimum distance from the object being illuminated is 2 MT.

5.5- Forced ventilation

You will note, on inspection, that the unit features various air inlets and cooling fans located on both the base and head of the fixture. These should, under no circumstances, be blocked or obstructed whilst the projector is in operation.

Doing so could cause the fixture to seriously overheat thereby compromising its proper operation.

5.6- Ambient temperature

The projector should never be installed in places that lack a constant air flow. The ambient temperature should NOT exceed 40°C.

6- MAINS CONNECTION

XR8 with electronic ballast operate at 90-245 VOLT 50-60 Hz.

XR8 with electromagnetic ballast operate at 230 VOLT 50-60 Hz

(On request: 100 V 50-60 Hz / 120 V 60 HZ / 208 V 60 Hz)

Prior to connecting the unit to your mains supply,

ensure that the model in your possession correctly matches

the mains supply available. For connection purposes,

ensure that your plug is capable of supporting 6,3 amps at 208-230V,

Or 16 amps at 100-120 V

Strict adherence to regulatory norms is strongly recommended.



Electronic ballast
90-245V 50 / 60Hz
Electromagnetic ballast
230 V 50/60 Hz (standard)
On request: 100 V 50-60 Hz
120 V 60 HZ / 208 V 60 Hz

6.1- Protection

The use of a thermal magnetic circuit breaker is recommended for each XR 8.

A good earth connection is essential for the correct operation of the projector.

7- DMX SIGNAL CONNECTION

The unit operates using the digital DMX 512 (1990) signal. Connection between the mixer and the projector or between projectors must be carried out using a two pair screened \varnothing 0.5 mm cable and a CANNON XLR 5 or 3 pins connector.

Ensure that the conductors do not touch each other. Do not connect the cable ground to the XLR chassy. The plug housing must be isolated. Connect the mixer signal to the DMX IN projector plug and connect it to the next projector by connecting the DMX OUT plug on the first projector to the DMX IN plug of the second one.

In this way, all the projectors are cascade connected.

NB. If the display showing the DMX address flashes, then one of the following errors has occurred:

- DMX signal not present
- DMX address not valid
- DMX reception problem



For Installations where long distance DMX cable connections are needed, we suggest to use a DMX terminator.

The DMX terminator is a male XLR 3-5 pins connector with a 120 ohm resistor between pin 2 and 3.

The DMX terminator must be plugged into the last unit (DMX out panel connector) of the DMX line.

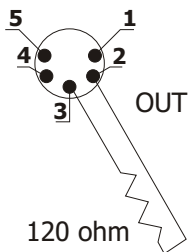

PLACE A 120 OHM RESISTOR BETWEEN PIN 2 AND 3 OF A MALE XLR CONNECTOR AND PLUG IT INTO THE DMX OUT PANEL CONNECTOR OF THE LAST UNIT CONNECTED TO THE DMX LINE

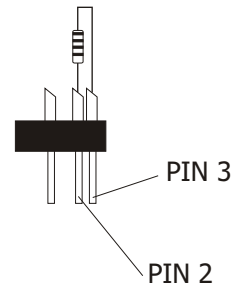

The standard configuration of the XR8 is with XLR 5 pins connection.

To convert to an XLR 3 pins configuration proceed as follows:

- 1) Remove the 2 screws fixing the display cover panel to the unit (photo 1).
- 2) Remove the screws that fix the XLR connectors to the panel (photo 2).
- 3) Rotate the electronic card by 180° (photo 3).
- 4) Place the 3 pins XLR connectors in the special holes and close.



Photo 1



Photo 2

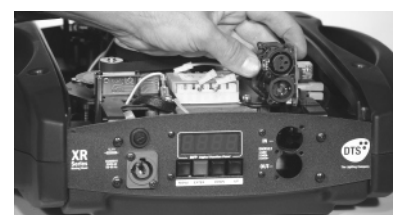

Photo 3

7.1-DMX Addresses

XR8 can be used in two different modes: 16 or 20 DMX (default) channels.

If you want to use the XR8 in 16 channels mode, select the 16 CH mode from the MODE menu and set the following addresses on the mixer:

Projector 1	A001	
Projector 2	A017	If you want to select the next projector, just add "16"
Projector 3	A033	
.....	A....	
projector 6	A081	

If you want to use the XR8 in 20 channels mode, select the 20 CH mode from the MODE menu and set the following addresses:

Projector 1	A001	
Projector 2	A021	If you want to select the next projector, just add "20"
Projector 3	A041	
.....	A....	
Projector 6	A101	

7.2-Selecting the DMX address

1) Press the UP-DOWN key until you reach the required DMX channel. The numbers on the display will start to flash (but the new DMX address hasn't yet been set).

2) Press ENTER to confirm your selection. The numbers on the display will stop flashing and the projector is now setted to the new DMX address.

TRICKS:

if you keep pushed the UP or DOWN keys, the channels are calculated more quickly and you get a faster selection.

8- DISPLAY FUNCTIONS



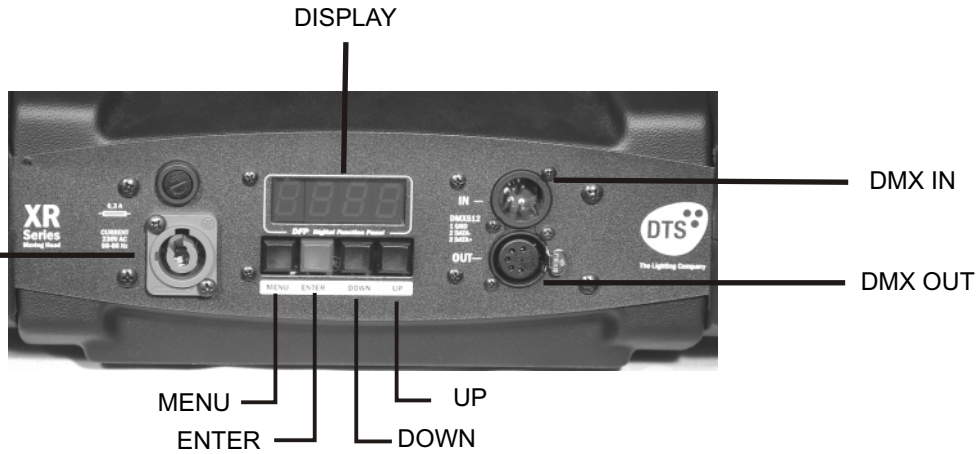

























MAINS
 Electronic ballast
 90-245V 50 / 60Hz
 Electromagnetic ballast
 230 V 50/60 Hz (standard)
 On request: 100 V 50-60 Hz
 120 V 60 HZ / 208 V 60 Hz



DISPLAY FUNCTIONS

The XR8 display panel shows all the available functions . Using these functions, it is possible to change some of the parameters and add some functions. Changing the DTS setting can vary the functions of the unit so that it does not respond to the DMX 512 used to control it. Carefully follow the instructions below before carrying out any variations or selections.

NOTE: the symbol  shows which key has to be pushed to obtain the desired function.

<p>ADD 1  </p> <p>Pd ir  </p>	<p>CU Clockwise </p> <p>CCU Counterclockwise </p>
<p>PAN MOVEMENT INVERSION To reverse Pan movement from left to right and vice versa</p>	
<p>td ir  </p> <p>CU Clockwise </p> <p>CCU Counterclockwise </p>	<p>CU Clockwise </p> <p>CCU Counterclockwise </p>
<p>TILT MOVEMENT INVERSION To reverse Tilt movement from bottom upwards and vice versa</p>	
<p>dISP  </p> <p>POS 1  </p> <p>Stby </p>	<p>AA Floor position </p> <p>BB Suspension position </p> <p>off Display OFF </p> <p>on Display always ON </p>
<p>REVERSE DISPLAY Reverses display's reading depending on the mounting position (On the ground or suspended).</p>	
<p>DISPLAY STAND BY To turn off the display (after 5 seconds) Or leave it always on.</p>	
<p>node  </p> <p>20CH  </p> <p>16CH </p>	<p>20 CHANNELS (Pan & Tilt 16 bit) </p> <p>16 CHANNELS (Pan & Tilt 16 bit) </p>
<p>DMX MODE To select DMX mode : 20-16 channels</p>	

8- DISPLAY FUNCTIONS

			<p>ALL </p> <p>PAN </p> <p>TILT </p> <p>DIMMER </p> <p>SHUTTER </p> <p>GOBO </p> <p>GOBO ROT </p>	<p>GOBO SHAKE </p> <p>EFFECTS </p> <p>EFFECTS ROT. </p> <p>COLOR </p> <p>FOCUS </p> <p>ZOOM </p> <p>FROST </p>					
<p>AUTOMATIC MODE Automatic game without DMX controller</p>									
				<p>RESET ENABLED VIA DMX </p>					
<p>RESET All motors reset</p>									
				<p>RESET DISABLED VIA DMX </p>					
<p>TOTAL RESET </p>									
<p>DEFAULT To restore default setting</p>									
				<p>SOFTWARE Software version</p> <p>Pcb 8 motors. Pcb PAN&TILT</p>					
<p>Fan control To control the fan speed .</p>									
			<p>(DEFAULT : 12)</p>						
<p>SPEED control Pan Tilt Speed control.</p>									
			<p>(DEFAULT : 2)</p>						
					<p>GOBO ROTATION DISABLE</p>				
<p>GOBO Rotation Gobo Rotation during gobo scrolling</p>									
			<p>GOBO ROTATION ENABLE</p>						
					<p>FOCUS STEPPER MOTOR TYPE 1</p>				
<p>FOCUS Focus stepper motor settings</p>									
			<p>FOCUS STEPPER MOTOR TYPE 2</p>						

8- DISPLAY FUNCTIONS

<p> LAMP</p> <p>LAMP Lamp always ON-always OFF Or lamp ON-OFF selectable via DMX</p>	<p> dnH</p> <p> on</p> <p> off</p>	<p> ON / OFF VIA DMX (default)</p> <p> FORCED ON</p> <p> FORCED OFF</p>	
<p>ADJUST To adjust the lamp with no mixer connected. It's possible to set the parameters for PAN-TILT and FOCUS</p>	<p> AdU</p>	<p> PAn</p> <p> tILT</p> <p> FOCU</p>	<p> 128</p> <p> 128</p> <p> 128</p>
<p>ACC Lamp strikes counter</p>	<p> ACC</p>	<p> 10</p>	
<hr/>			
<p> REC</p> <p>REC Record mode</p>	<p> 16CH</p>	<p> r.017</p>	
<hr/>			
<p> SLAU</p> <p>Slave Slave mode as run by GAM.P, Synchronised with master</p>	<p> SUR</p>	<p> SLU</p> <p> ESC</p>	
<hr/>			
<p> rSUD</p> <p>RESERVED Pan lock-Tilt lock Pan free-Tilt free</p>	<p> Code</p>	<p> 100</p>	<p> </p>
<p>PAN LOCK LOCK THE PAN TO THE DESIRED VALUE</p>	<p> PnLH</p>	<p> no</p> <p> YES</p>	<p> 128</p>
<p>TILT LOCK LOCK THE TILT TO THE DESIRED VALUE</p>	<p> tLLH</p>	<p> no</p> <p> YES</p>	<p> 128</p>
<p>PAN FREE REMOVE POWER TO PAN MOTOR</p>	<p> PnFr</p>	<p> no</p> <p> YES</p>	
<p>TILT FREE REMOVE POWER TO TILT MOTOR</p>	<p> tLFr</p>	<p> no</p> <p> YES</p>	
<p> tIME</p> <p>TIMER lamp life TIME (reset possible) and total UNIT LIFE TIME (reset not possible)</p>	<p> LAMP</p> <p> Unit</p> <p> rESL</p>	<p> 4</p> <p> 8</p> <p> SUR</p>	<p></p>

9- AUTOMATIC MODE (auto)

XR8 can work in automatic mode without a DMX controller.
First of all connect the projectors with a DMX cable (picture below).



To activate Auto mode on the first unit, use the menu to run through the different modes until AUTO appears on the display, at this point press enter.

Now it is possible to select the Game P which is user programmable through REC mode.

To confirm game activation press ENTER.

9.1- Game P

The first unit that will function as a Master must be put in (AUTO) mode, the other projectors have to be put in slave mode (selectable through the menu). This way all units will be synchronised with the master. Please note that the projectors must be of the same model.

On the master unit it is possible to vary the speed of the GAME P (SPEE)

NB: It is possible to run GAME P on the other units even though these do not have GAME P programmed. You can do this by setting the units to the same mode as the master is set before programming GAME P (16CH DMX) and setting the DMX address to A001.

9.2-Rec Mode

It is possible to program your own game on the XR8 that will then run in AUTO mode (GAME P). Each unit can have its own programmed game.

In REC mode each projector must be set to the same mode (16CH DMX).

For the programming of GAME P besides the channels necessary to control the unit a further 3 DMX channels are needed. So that in REC mode if the 16CH mode is selected you will need 19 channels for the program to work correctly.

Connect the unit to a DMX mixer/controller, every unit should be set to its own Address (See the paragraph on DMX addresses). The projectors can also be of different models:XR8 Spot/Wash, XR7 Spot/Wash and XR 250 Spot/Wash. When you are in REC mode R.001 appears on the display (DMX address).

The three new DMX channels are:

-Scene channel

-From 0-255 are displayed the programmable scenes (max 16 scenes M.001 M016)

-View channel:

-From 1-19 the unit runs the scene that has been saved in the unit memory and it is possible to play through the other scenes using the scene channel.

-From 20-235 the unit runs the configuration given by the received input DMX values. With the channel scene it is possible to pass from one scene to the next, while with REC it is possible to record the selected scene.

-From 236-255 the unit runs the configuration given by the received DMX values from the projector in that moment. It is possible to select a scene and then close the GAME P with the REC channel.

-Recording channel (REC)

Records the set scene with a variation from 0 to 255 (the display flashes indicating that the scene has been recorded).

You must keep the REC channel set to 0 and to run through the 255 only once you have decided to save the scene. If GAME P is not closed, by indicating the last scene, in playback mode all 16 scenes will be played through even if not programmed.

10- PAN & TILT SPEED (SPEE) (default: 2)

You can set the PAN and TILT motors at high speed on your XR8.

Press menu until you see SPEE.













Press ENTER and select a speed with UP-DOWN (there are 4 speeds). Confirm by pressing ENTER.

When you use speed 4 (the highest) PAN and TILT speed is very high and your projector may lose its path. In this case, the encoder corrects the position.

11- FAN SPEED (FANS)(default: 12)

Fan speed regulation makes it possible to reduce fan noise. However, the ambient temperature must be less than 35° C.

12- ERROR MESSAGES:

	— ERROR: ENCODER PAN		— ERROR: COLOR WHEEL POSITION
	— ERROR: ENCODER TILT		— ERROR: GOBO WHEEL POSITION
	— ERROR: DMX ADDRESS		— ERROR: ZOOM POSITION
	— ERROR: LOAD DATA EEPROM		— ERROR: GOBO ROTATION POSITION
	— ERROR: SENSOR CIRCUIT COLOR/ZOOM		— ERROR: INTERNAL COMMUNICATION
	— ERROR: SENSOR CIRCUIT GOBO/GOBO ROTATION		— ERROR: AUTO MODE INPUT
	— ERROR: SYNCHRONIZED FREQUENCY MEASURE (SYNCHRONISM FOR LAMP ON)		

13- HIDDEN MENU

For technical personnel only.

To operate this menu:

- Connect the projector to the DMX controller (DMX SIGNAL MUST BE CORRECTLY RECEIVED)
- Reset the XR8 (reset from the MENU, not from the DMX controller!).
- While reset is running, press the MENU and ENTER keys at the same time.

CAL

Electronic calibration of the motors.

RESN

Reset EEPROM (Reset all settings. ATTENTION: by pressing this key you must repeat all previous calibrations)

ESC

Exit from hidden menu.

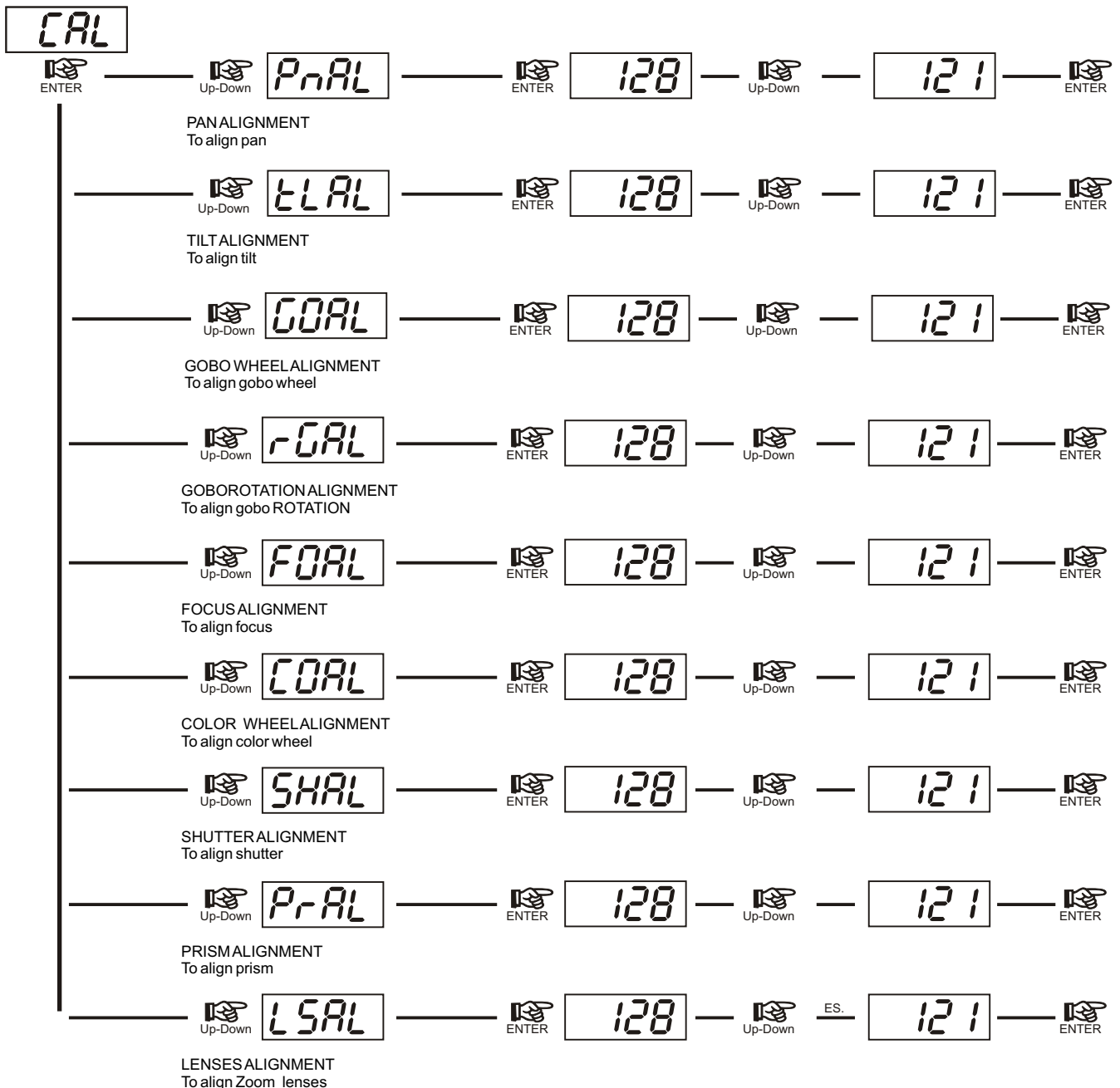

14- OPENING THE PROJECTOR HOUSING

It is possible to inspect the inside of the projector by removing the cover as indicated below.

ATTENTION

REMOVE MAINS POWER PRIOR TO ACCESSING THE PROJECTOR'S INTERNAL COMPONENTS.

- 1) Loosen the 3 (1/4 turn) screws which fix the head covers (photo 1) .
- 2) Once unscrewed, simply lift the covers to access the internal components (photo 2).



Photo 1



Photo 2

15- REPLACING GOBOS

XR8 uses a mechanical system which allows the fixture's gobos to be removed without the use of special tools. Replacement gobos should be made of either heat resistant glass or metal. An ever-increasing range of gobos is available from your D.T.S. sales network.

Gobo dimensions are as follows:

∅ external = 27.9 mm

∅ of image with defined edge = 24 mm

thickness = from 0.2 to 4 mm (see catalogue)

Replacing gobos on the rotating gobo wheel!

When replacing gobos, ensure that the projector is switched off.

- 1) Open the projector housing as described above.
- 2) Remove the gobo holder to allow easier access to the gobo(photo 1 and 2).
- 3) Release the gobo retaining spring and carefully remove the gobo (photo 3).
- 4) Reverse the procedure to install a replacement gobo.



Photo 1

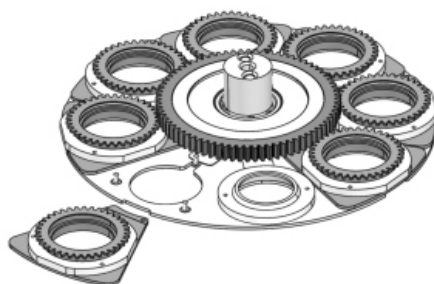

Photo 2

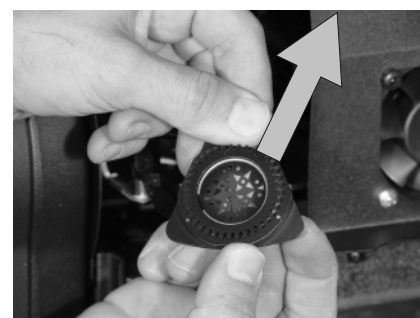

Photo 3

16- PERIODIC CLEANING

16.1- Lenses and reflectors

Even a fine layer of dust can substantially reduce the luminous output . Regularly clean all lenses and the reflector using a soft cotton cloth, dampened with a specialist lens cleaning solution.

16.2- Fans and air passages

The fans and air passages must be cleaned approximately every 6 weeks. This periodic cleaning will depend of course, on the conditions in which the projector is operating. Suitable instruments for performing this type of maintenance are a brush and a common vacuum cleaner or an air compressor. If necessary, clean the fans and air passages more frequently.

17- PERIODIC CONTROLS

Lamp

The lamp should be replaced if there is any visible damage or deformation due to heat. This will help to avoid the danger of the lamp exploding.

Mechanical parts

Periodically check all mechanical parts, gears, guides, belts, etc. for wear and tear, replacing them if necessary. Periodically check the lubrication of all components, particularly the parts subject to high temperatures. If necessary, lubricate with suitable lubricant, available from your D.T.S. distributor. Check the tension of the belts and adjust it if necessary.

Electrical components

Check all electrical components for correct earthing and proper connection of all connectors; refasten them if necessary.

Fuse replacement

Locate the fuse, which protects the lamp and electronics, in the base of the XR8.

Using a multimeter, test the condition of the fuse, replacing it with one of equivalent type if necessary.

Attention

Disconnect mains power prior to removing the projector housing.

18- DMX PROTOCOL

16 CHANNELS MODE

- 1 PAN msb 540°
- 2 PAN lsb
- 3 TILT msb 270°
- 4 TILT lsb
- 5 SPEED MOVEMENT
- 6 DIMMER
- 7 SHUTTER
- 8 COLOUR
- 9 COLOUR PROPORTIONAL (Priority in color channel)
- 10 GOBO
- 11 GOBO ROTATION
- 12 PRISM/PRISM ROTATION
- 13 FOCUS
- 14 ZOOM
- 15 FROST (Priority on Zoom channel)
- 16 LAMP ON-OFF / RESET

DMX CHANNEL	1	Parameter: PAN msb
-------------	---	---------------------------

DMX CHANNEL	2	Parameter: PAN lsb
-------------	---	---------------------------

DMX CHANNEL	3	Parameter: TILT msb
-------------	---	----------------------------

DMX CHANNEL	4	Parameter: TILT lsb
-------------	---	----------------------------

DMX CHANNEL	5	Parameter: MOVEMENT SPEED
-------------	---	----------------------------------

DMX range Value	Mid point DMX value	Move range (degrees)	Mode	Option	Function
0-10	5				Standard
11-25	18				Fast movement
26-127	76				Vector mode from fast to slow
128-247	187				Variable time reaction to DMX signal (fast to slow)
248-255	251				Slow reaction time to DMX signal

DMX CHANNEL	6	Parameter: DIMMER
-------------	---	--------------------------

DMX range Value	Mid point DMX value	Move range (degrees)	Mode	Option	Function
-----------------	---------------------	----------------------	------	--------	----------

0-8	4				Black-out
9-255					Proportional dimmer

DMX CHANNEL	7	Parameter: SHUTTER
-------------	----------	---------------------------

DMX range Value	Mid point DMX value	Move range (degrees)	Mode	Option	Function
0-9	5				Black-out
10-23	16				Strobe random speed
24-37	30				Strobe speed 1 min.
38-51	44				Strobe speed 2
52-65	58				Strobe speed 3
66-79	72				Strobe speed 4
80-93	86				Strobe speed 5
94-107	100				Strobe speed 6 max.
108-121	114				Pulse open speed 1 min.
122-135	128				Pulse open speed 2
136-149	142				Pulse open speed 3
150-163	156				Pulse open speed 4 max.
164-177	170				Pulse closed speed 1 min.
178-191	184				Pulse closed speed 2
192-205	198				Pulse closed speed 3
206-219	212				Pulse closed speed 4 max.
220-227	225				Colour and Gobo in black-out
228-233	230				Pan and Tilt in black-out
234-255	244				Open

DMX CHANNEL	8	Parameter: COLOUR
-------------	----------	--------------------------

DMX range Value	Mid point DMX value	Move range (degrees)	Mode	Option	Function
0-10	5				Colour1
11-21	16				Bicolour ½
22-32	27				Colour2
33-43	38				Bicolour 2/3
44-54	49				Colour3
55-65	60				Bicolour 3/4
66-76	71				Colour4
77-87	82				Bicolour 4/5
88-98	93				Colour5
99-109	104				Bicolour 5/6
110-120	115				Colour6
121-131	126				Bicolour 6/7
132-142	137				Colour7
143-153	148				Bicolour 7/8
154-164	159				Colour8

165-175	170				Bicolour 8/9
176-186	181				Colour9
187-197	192				Bicolour 9/1
198-200	199				Right rotation speed 1 min.
201-203	200				Right rotation speed 2
204-206	205				Right rotation speed 3
207-209	208				Right rotation speed 4
210-212	211				Right rotation speed 5
213-215	214				Right rotation speed 6
216-218	217				Right rotation speed 7
219-221	220				Right rotation speed 8
222-224	223				Right rotation speed 9 max.
225-228	226				Stop
229-231	230				Left rotation speed 1 min.
232-234	233				Left rotation speed 2
235-237	236				Left rotation speed 3
238-240	239				Left rotation speed 4
241-243	242				Left rotation speed 5
244-246	245				Left rotation speed 6
247-249	248				Left rotation speed 7
250-252	251				Left rotation speed 8
253-255	254				Left rotation speed 9 max.

DMX CHANNEL	9	Parameter: PROPORTIONAL COLOUR (PRIORITY)
-------------	---	--

DMX range Value	Mid point DMX value	Move range (degrees)	Mode	Option	Function
0-10	5				No effect
11-255					Proportional colour

DMX CHANNEL	10	Parameter: GOBO
-------------	----	------------------------

DMX range Value	Mid point DMX value	Move range (degrees)	Mode	Option	Function
0-25	12				Open
26-51	38				Gobo 1
52-77	64				Gobo 2
78-103	90				Gobo 3
104-129	116				Gobo 4
130-155	142				Gobo 5
156-181	168				Gobo 6
182-207	194				Gobo 7
208-213	210				Speed rotation 1 min.
214-219	216				Speed rotation 2
220-225	222				Speed rotation 3
226-231	228				Speed rotation 4
232-237	234				Speed rotation 5
238-243	240				Speed rotation 6

244-249	246				Speed rotation 7
250-255	252				Speed rotation 8 max.

DMX CHANNEL	11	Parameter: ROTO GOBO			
-------------	-----------	-----------------------------	--	--	--

DMX range Value	Mid point DMX value	Move range (degrees)	Mode	Option	Function
0-127					Proportional from 0° to 360°
128-180					Left rotation
181-202	191				Stop
203-255					Right rotation

DMX CHANNEL	12	Parameter: PRISM/ROTOPRISM			
-------------	-----------	-----------------------------------	--	--	--

DMX range Value	Mid point DMX value	Move range (degrees)	Mode	Option	Function
0-63	32				No effect
64-127	95				Prism
128-191					Left rotation
192-255					Right rotation

DMX CHANNEL	13	Parameter: FOCUS			
-------------	-----------	-------------------------	--	--	--

DMX range Value	Mid point DMX value	Move range (degrees)	Mode	Option	Function
0-255					proportional

DMX CHANNEL	14	Parameter: LIGHT BEAM ANGLE			
-------------	-----------	------------------------------------	--	--	--

DMX range Value	Mid point DMX value	Move range (degrees)	Mode	Option	Function
0-84	42				11°
85-170	127				15°
171-255	213				18°

DMX CHANNEL	15	Parameter: FROST (PRIORITY)			
-------------	-----------	------------------------------------	--	--	--

DMX range Value	Mid point DMX value	Move range (degrees)	Mode	Option	Function
0-127	63				No lens
128-255	191				Frost

DMX CHANNEL	16	Parameter: RESET
-------------	----	-------------------------

DMX range Value	Mid point DMX value	Move range (degrees)	Mode	Option	Function
0-9	5				No Effect
10-60	30				Lamp OFF (Active after 3 seconds)
61-129	95				No Effect
130-179	154				Lamp ON (Active after 3 seconds)
180-200	190				No Effect
201-239	220				Internal Motors Reset
240-255	247				Total Reset

20 CHANNELS MODE (DEFAULT)

- 1 PAN msb 540°**
- 2 PAN lsb**
- 3 TILT msb 270°**
- 4 TILT lsb**
- 5 P/T SPEED MOVEMENT**
- 6 DIMMER**
- 7 SHUTTER**
- 8 COLOUR**
- 9 COLOUR MODE**
- 10 GOBO**
- 11 GOBO MODE**
- 12 GOBO ROTATION-INDEX**
- 13 GOBO ROTATION-INDEX FINE**
- 14 GOBO SHAKE**
- 15 PRISM**
- 16 PRISM ROTATION**
- 17 FOCUS**
- 18 ZOOM**
- 19 FROST (Priority on Zoom channel)**
- 20 LAMP ON-OFF / RESET**

DMX CHANNEL	1	Parameter: PAN msb
-------------	----------	---------------------------

DMX CHANNEL	2	Parameter: PAN lsb
-------------	----------	---------------------------

DMX CHANNEL	3	Parameter: TILT msb
-------------	----------	----------------------------

DMX CHANNEL	4	Parameter: TILT lsb
-------------	----------	----------------------------

DMX CHANNEL	5	Parameter: MOVEMENT SPEED
-------------	----------	----------------------------------

DMX range Value	Mid point DMX value	Move range (degrees)	Mode	Option	Function
0-10	5				Standard
11-25	18				Fast movement
26-127					Vector mode from fast to slow
128-247					Variable time reaction to DMX signal (fast to slow)
248-255					Slow reaction time to DMX signal

DMX CHANNEL	6	Parameter: DIMMER
-------------	---	--------------------------

DMX range Value	Mid point DMX value	Move range (degrees)	Mode	Option	Function
0-8	4				Black-out
9-255					Linear dimmer

DMX CHANNEL	7	Parameter: SHUTTER
-------------	---	---------------------------

DMX range Value	Mid point DMX value	Move range (degrees)	Mode	Option	Function
0-19					Black-out
20-39					Open
40-59					Black-out
60-79					Random Strobe
80-89					Strobe speed 1 min.
90-99					Strobe speed 2
100-109					Strobe speed 3
110-119					Strobe speed 4
120-129					Strobe speed 5
130-139					Strobe speed 6 max.
140-149					Pulse open speed 1 min.
150-159					Pulse open speed 2
160-169					Pulse open speed 3
170-179					Pulse open speed 4 max.
180-189					Pulse closed speed 1 min.
190-199					Pulse closed speed 2
200-209					Pulse closed speed 3
210-219					Pulse closed speed 4 max.
220-227					Colour and Gobo in black-out
228-233					Pan and Tilt in black-out
234-255					Open

DMX CHANNEL	8	Parameter: COLOUR
-------------	---	--------------------------

DMX range Value	Mid point DMX value	Move range (degrees)	Mode	Option	Function
IF CHANNEL 9 = FULL COLOUR (Dmx range value 0 - 63)					
0-27					Colour1
28-55					Colour2
56-83					Colour3
84-111					Colour4
112-139					Colour5
140-167					Colour6
168-195					Colour7
196-223					Colour8
224-255					Colour9

DMX CHANNEL	8	Parameter: COLOUR
-------------	----------	--------------------------

DMX range Value	Mid point DMX value	Move range (degrees)	Mode	Option	Function
IF CHANNEL 9 = HALF COLOUR (Dmx range value 64 - 127)					
0-25					No Colour
26-51					Bicolour ½
52-77					Bicolour 2/3
78-103					Bicolour 3/4
104-129					Bicolour 4/5
130-155					Bicolour 5/6
156-181					Bicolour 6/7
182-207					Bicolour 7/8
208-233					Bicolour 8/9
234-255					Bicolour 9/1
IF CHANNEL 9 = PROPORTIONAL COLOUR (Dmx range value 128 - 191)					
0-10					No Colour
11-255					Proportional colour
IF CHANNEL 9 = RAINBOW (Dmx range value 192 - 255)					
0-9					No Colour
10-127					Right Rot.Speed from Max to Min
128-137					Stop
138-255					Left Rot.speed from Min to Max

DMX CHANNEL	9	Parameter: COLOUR MODE
-------------	----------	-------------------------------

DMX range Value	Mid point DMX value	Move range (degrees)	Mode	Option	Function
0-63					Full Colour
64-127					Half Colour
128-191					Proportional Colour
192-255					Rainbow

DMX CHANNEL	10	Parameter: GOBO
-------------	-----------	------------------------

DMX range Value	Mid point DMX value	Move range (degrees)	Mode	Option	Function
0-25					Open
26-51					Gobo 1
52-77					Gobo 2
78-103					Gobo 3
104-129					Gobo 4
130-155					Gobo 5
156-181					Gobo 6
182-207					Gobo 7
208-213					Rotation speed 1 min.

DMX CHANNEL	10	Parameter: GOBO
-------------	-----------	------------------------

DMX range Value	Mid point DMX value	Move range (degrees)	Mode	Option	Function
214-219					Rotation speed 2
220-225					Rotation speed 3
226-231					Rotation speed 4
232-237					Rotation speed 5
238-243					Rotation speed 6
244-249					Rotation speed 7
250-255					Rotation speed 8 Max

DMX CHANNEL	11	Parameter: GOBO MODE
-------------	-----------	-----------------------------

DMX range Value	Mid point DMX value	Move range (degrees)	Mode	Option	Function
0-127					Gobo Rotation Mode
128-255					Gobo Index Mode

DMX CHANNEL	12	Parameter: GOBO ROTATION/GOBO INDEX
-------------	-----------	--

DMX range Value	Mid point DMX value	Move range (degrees)	Mode	Option	Function
IF CHANNEL 11 = Gobo Rotation Mode (Dmx range value 0 - 127)					
0-9					Stop
10-127					DX Rot. Prop. Speed Max to Min
128-137					Stop
138-255					SX Rot. Prop. Speed Min to Max
IF CHANNEL 11 = Gobo Index Mode (Dmx range value 128 - 255)					
0-255					Gobo index Coarse

DMX CHANNEL	13	Parameter: GOBO INDEX FINE
-------------	-----------	-----------------------------------

DMX range Value	Mid point DMX value	Move range (degrees)	Mode	Option	Function
0-255					Gobo Index Fine

DMX CHANNEL	14	Parameter: GOBO SHAKE
-------------	-----------	------------------------------

DMX range Value	Mid point DMX value	Move range (degrees)	Mode	Option	Function
0-9					Stop
10-22					Gobo Shake R-L Speed 1 Min.
23-35					Gobo Shake R-L Speed 2
36-48					Gobo Shake R-L Speed 3

DMX CHANNEL	14	Parameter: GOBO SHAKE
-------------	----	------------------------------

DMX range Value	Mid point DMX value	Move range (degrees)	Mode	Option	Function
49-61					Gobo Shake R-L Speed 4
62-74					Gobo Shake R-L Speed 5
75-87					Gobo Shake R-L Speed 6
88-100					Gobo Shake R-L Speed 7
101-113					Gobo Shake R-L Speed 8
114-126					Gobo Shake R-L Speed 9 Max
127-138					Stop
139-151					Gobo Shake L-R Speed 1 Min
152-164					Gobo Shake L-R Speed 2
165-177					Gobo Shake L-R Speed 3
178-190					Gobo Shake L-R Speed 4
191-203					Gobo Shake L-R Speed 5
204-216					Gobo Shake L-R Speed 6
217-229					Gobo Shake L-R Speed 7
230-242					Gobo Shake L-R Speed 8
243-255					Gobo Shake L-R Speed 9 Max

DMX CHANNEL	15	Parameter: PRISM
-------------	----	-------------------------

DMX range Value	Mid point DMX value	Move range (degrees)	Mode	Option	Function
0-127					No Effect
128-255					3 Facet Prism

DMX CHANNEL	16	Parameter: PRISM ROTATION
-------------	----	----------------------------------

DMX range Value	Mid point DMX value	Move range (degrees)	Mode	Option	Function
0-9					Stop
10-121					Left Rot. Prop. Speed from Max to Min
122-143					Stop
144-255					Right Rot. Prop. Speed from Min to Max

DMX CHANNEL	17	Parameter: FOCUS
-------------	----	-------------------------

DMX range Value	Mid point DMX value	Move range (degrees)	Mode	Option	Function
0-255					Linear focus

DMX CHANNEL	18	Parameter: ZOOM
-------------	-----------	------------------------

DMX range Value	Mid point DMX value	Move range (degrees)	Mode	Option	Function
0-84					11°
85-170					15°
171-255					18°

DMX CHANNEL	19	Parameter: FROST
-------------	-----------	-------------------------

DMX range Value	Mid point DMX value	Move range (degrees)	Mode	Option	Function
0-127					No Effect
128-255					Frost

DMX CHANNEL	20	Parameter: LAMP / RESET
-------------	-----------	--------------------------------

DMX range Value	Mid point DMX value	Move range (degrees)	Mode	Option	Function
0-9	5				No Effect
10-60	30				Lamp OFF (Active after 3 seconds)
61-129	95				No Effect
130-179	154				Lamp ON (Active after 3 seconds)
180-200	190				No Effect
201-239	220				Internal Motors Reset
240-255	247				Total Reset

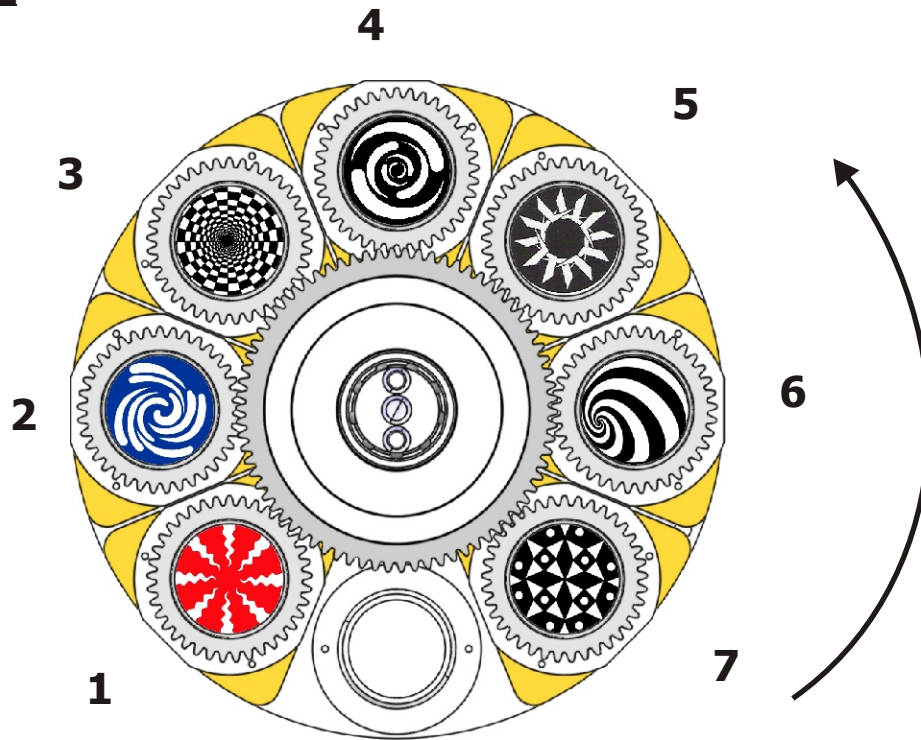
19- GOBO WHEEL**GOBO 1 DICHROIC**

0516G029.02

GOBO 2 DICHROIC

0516G029

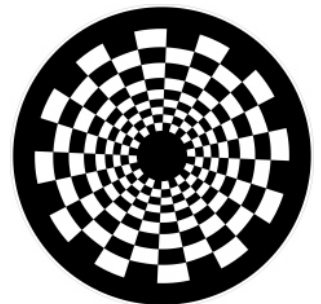
GOBO 3 DICHROIC

0516G029.01

GOBO 4 METAL

0516G030.01

GOBO 5 METAL

0516G030.02

GOBO 6 METAL

0516G030.03

GOBO 7 METAL

0516G030.04

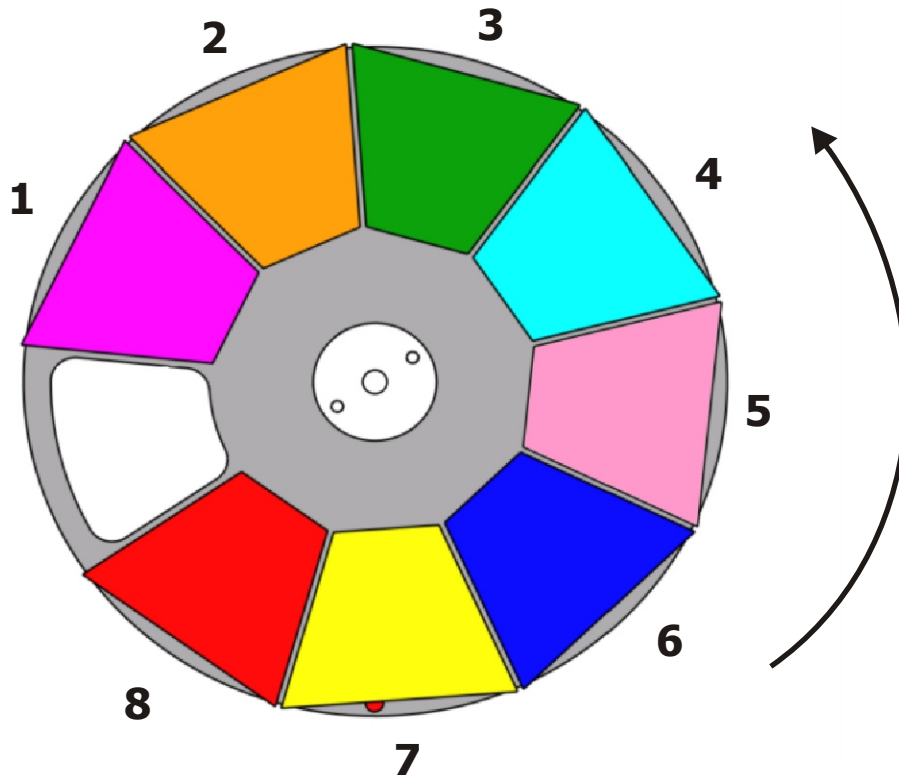
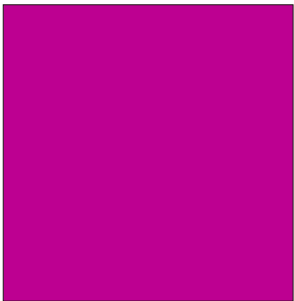
20- COLOUR WHEEL**COL1**

0507C043.D01
LAVANDER SL0064

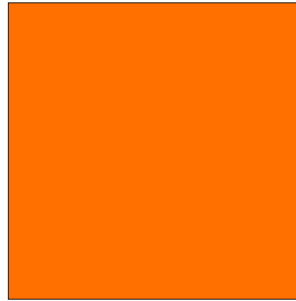
COL2

0507C051.D01
ORANGE LW590

COL3

0507C042.D01
GREEN WB5055

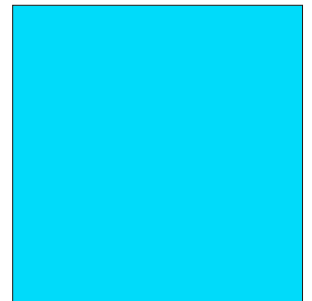
COL4

0507C045.D01
CYAN SW 530

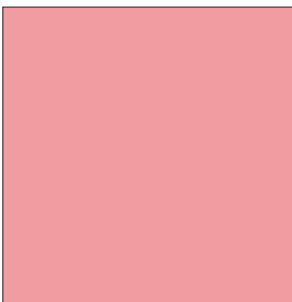
COL5

0507C052.D01
PINK SL4761

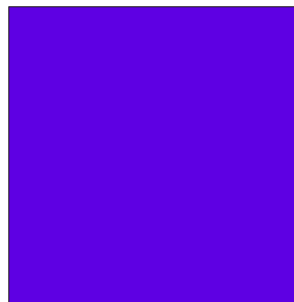
COL6

0507C041.D01
DARK BLUE SW490

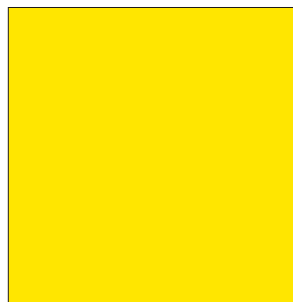
COL7

0507C049.D01
YELLOW LW 515

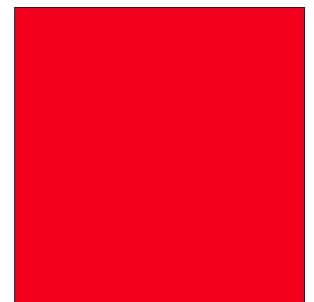
COL8

0507C047.D01
RED LW 640

21- MOTORS CONTROL CARD

8 MOTORS PCB

J7 Magnetic Sensors Connector

Line 1 Brown
Line 2 Orange

GND
ORANGE
BROWN
VCC

J9 from J3 Lamp ON-OFF control card

J1 Internal DATA Communication Connector From J8 Pan & Tilt card

30 VDC

Display

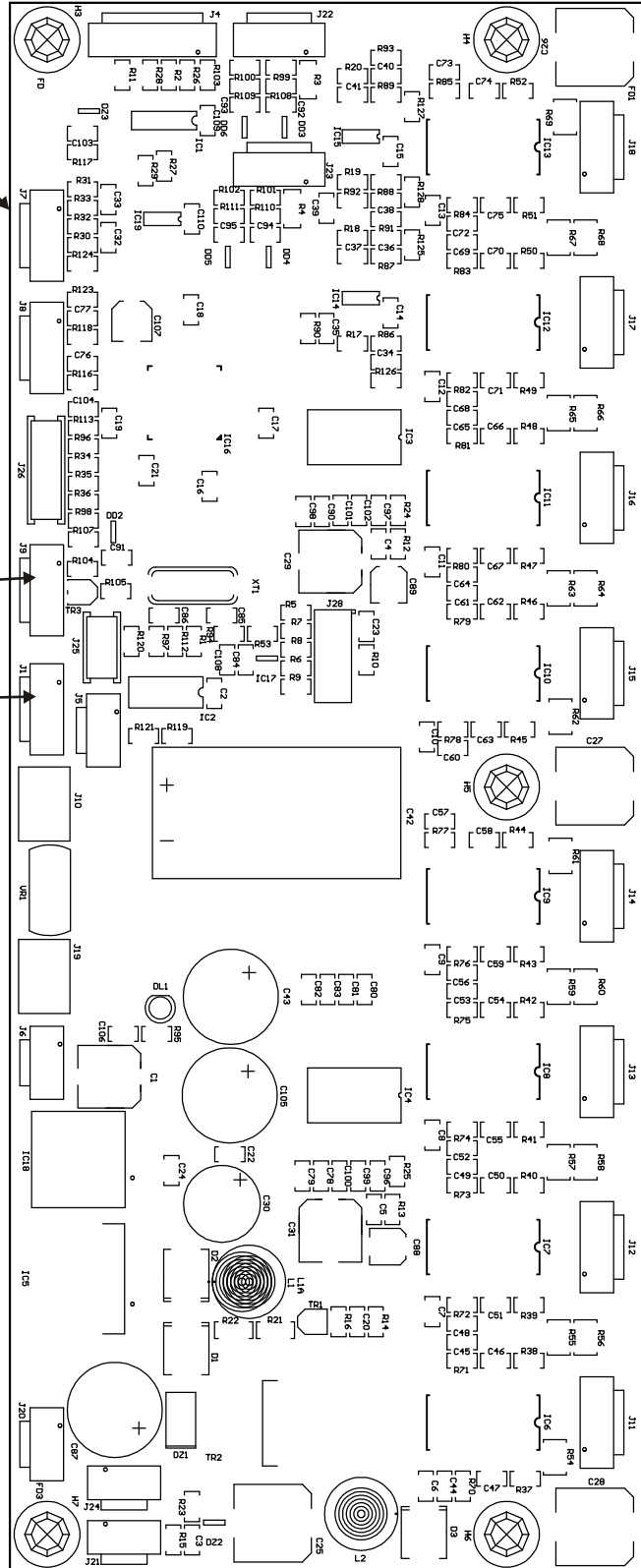

Gobo
(BLACK)

Focus
(DARK GREEN)

Strobe
(YELLOW)

Prism
(PINK)

Zoom
(GREY)

Gobo rotation
(LIGHT BLUE)

Prism rotation
(GOLD)

Colour
(BLUE)

Fans

22-PAN & TILT CARD

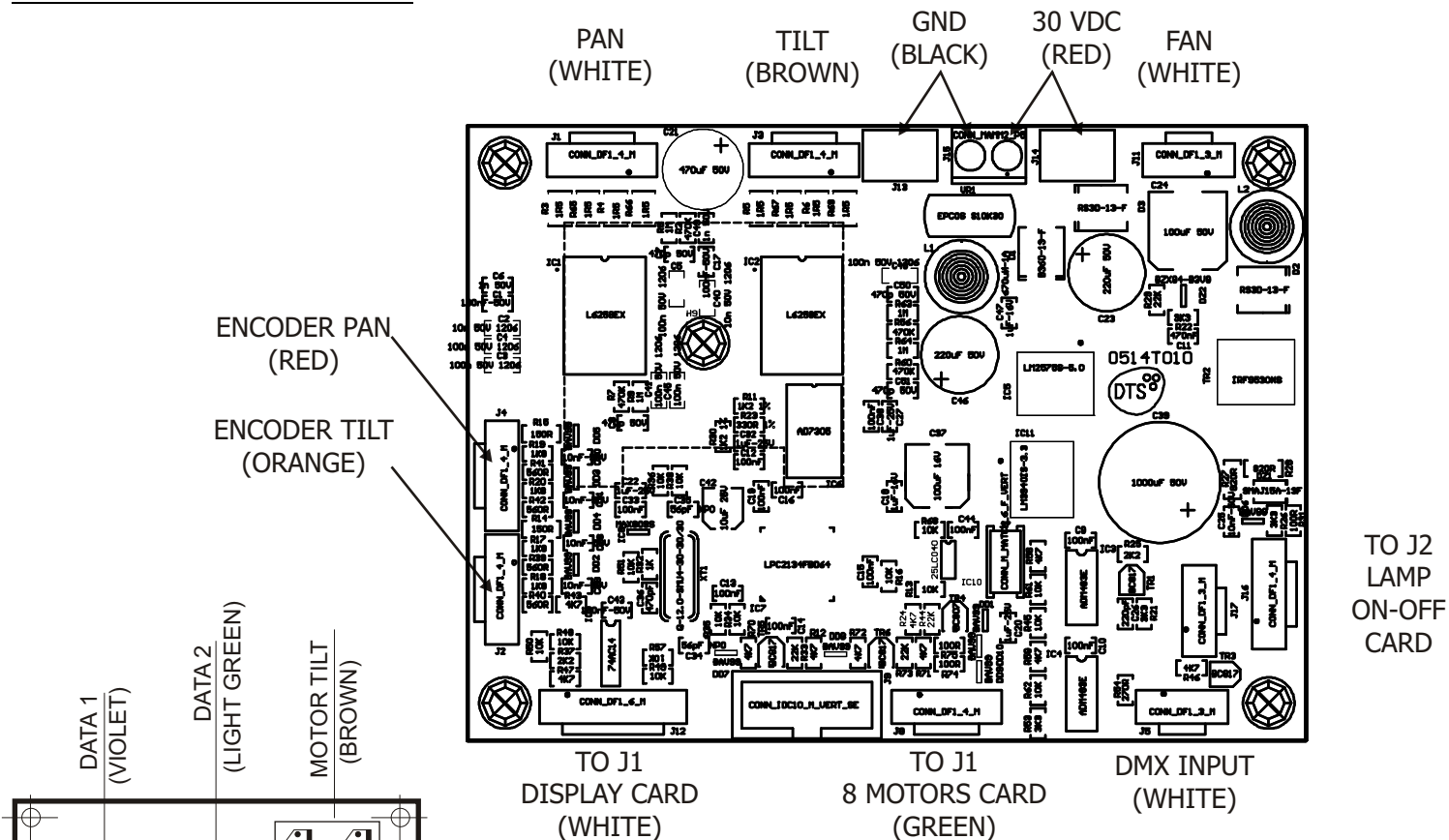

23-CABLES RESEND CARD



24-DISPLAY CARD

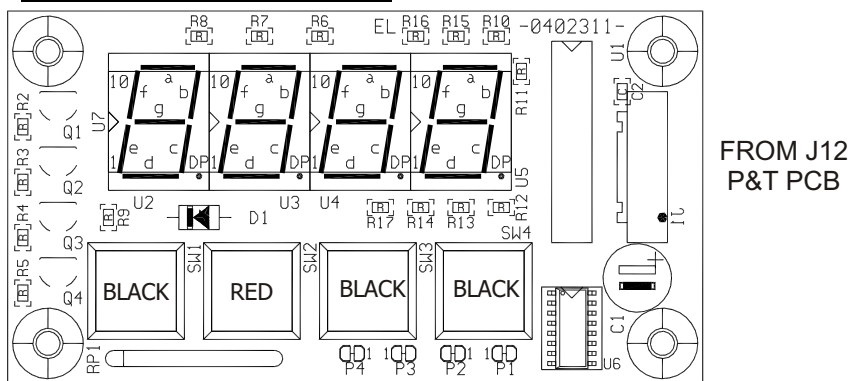

25-LAMP ON-OFF CONTROL CARD

If the PCB card doesn't work, move the cable "IN LAMP" from CN 1 to CN 7

To remove **SnEr** error from display, in

Menu **LAMP** select **OFF**

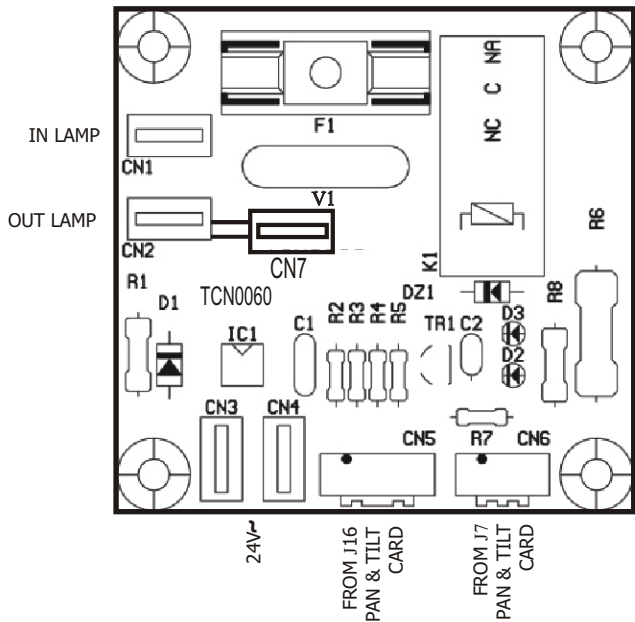

26- WIRING DIAGRAMS

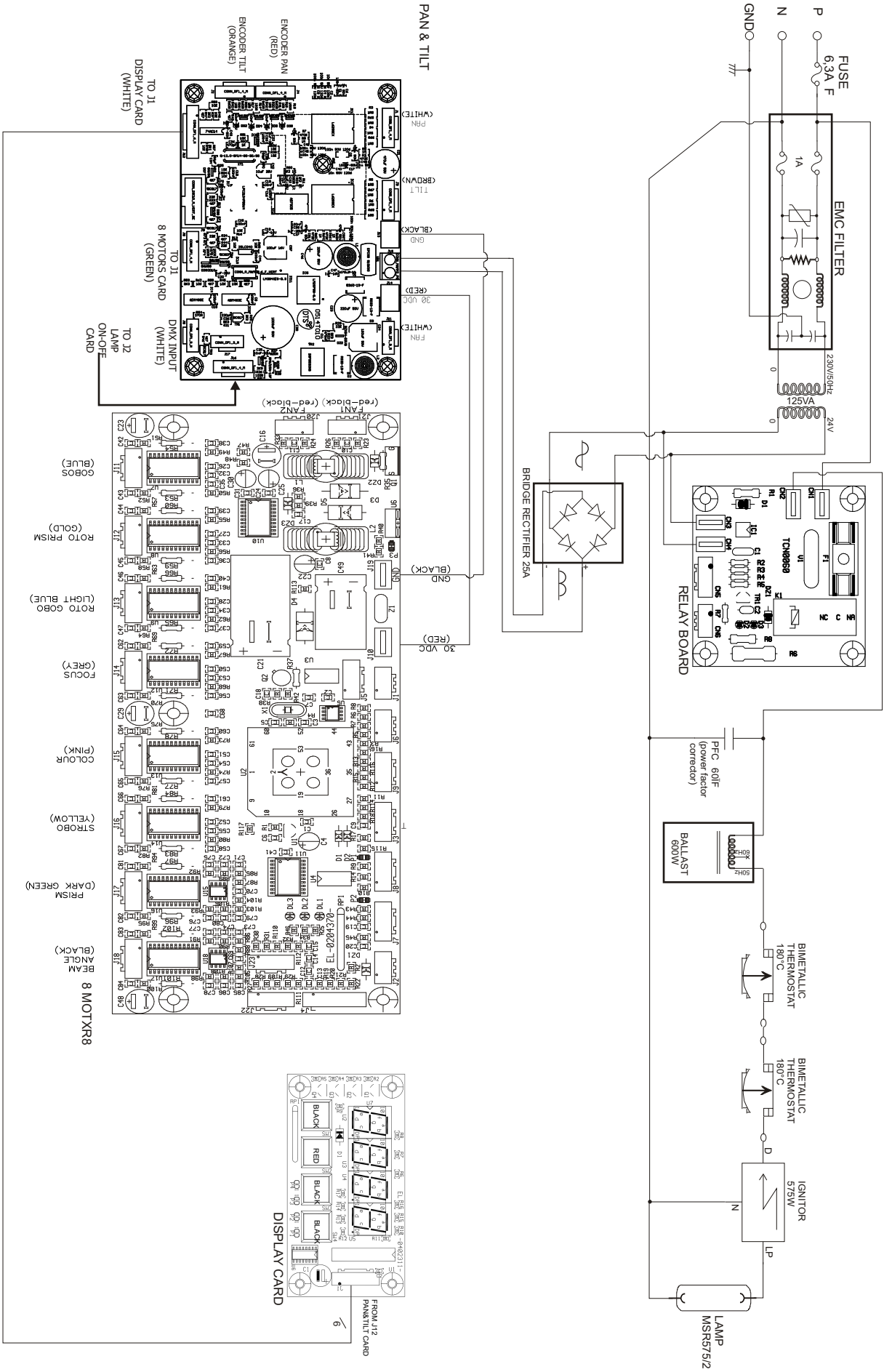

NOTES

The information contained in this publication has been carefully prepared and checked. However, no responsibility will be taken for any errors. All rights are reserved and this document cannot be copied, photocopied or reproduced, in part or completely, without prior written consent from D.T.S.

D.T.S. reserves the right to make any aesthetic, functional or design modifications to any of its products without prior notice. D.T.S. assumes no responsibility for the use or application of the products or circuits described herein.

MADE IN ITALY



The Lighting Company

ISO 9001:2000

D.T.S. quality system
is certified to the
ISO 9001:2000 standard



D.T.S. products are designed
and manufactured at the D.T.S.
plants in Italy



05171067