



## **XRLED 300 Spot**

**PR-8157**

The new LED Spot moving head XRLED 300 Spot comes out with the very eye-catching features.

### **Key features:**

- Power consumption: 240W@220V
- one 150-Watt white LED
- 1 color wheel with 8 colors + open
- 7 fixed gobos+ 7 rotating gobos
- Beam angle: 14°~30°
- One 3-facet prism
- Iris: 5°~100° linearly adjustable with macro
- Focus: DMX controlled focus
- Dimmer: 0-100% linearly adjustable
- Strobe: electronic strobe 0.3~20F.P.S
- Zoom: motorized zooming linearly adjustable
- 14 channels in short mode, 19 channels in standard mode and 23 channels in extended mode
- Head movement: Pan 540° or endless and Tilt 270° with auto position correction
- Others: preset memory, user memories, wireless DMX
- Net weight: only 17.5 Kg

### **Standard Accessories:**

G clamps, 2 pcs	5-pin XLR connectors, 1 set
Safety cord, 1 pc	Power cord, 1 pc

### **Optional Accessories:**

Ω clamps, 2 pcs

### **Power Supply:**

100~240V AC, 50/60Hz

1582 Xingye Avenue, Nancun, Panyu, Guangzhou, 511442, China  
+86-20-3995 2379 Fax.: +86-20-3995 2330 [www.pr-lighting.com](http://www.pr-lighting.com)

## Technical Data:

### Power Consumption:

240W@220V

### Light Source:

150W LED White

### Optics System:

14° ~30° linear zoom

### Colour System:

1 color wheel + 8 dichroic color filters + white

### Effects:

#### Gobos:

##### 1 Rotating gobo wheel:

7 interchangeable gobos+ white, glass or metal gobos can be fixed  
Indexable, bi-directionally rotatable and Wheel Scrolling at variable speeds,  
shakable at variable speeds

##### 1 Fixed gobo wheel :

7 interchangeable gobos+ white  
bi-directional wheel scrolling at variable speeds, shaking at variable speeds  
Gobo diameter:  $\Phi$ 24mm  
Gobo image diameter:  $\Phi$ 20mm

### Prism:

1x3 facet prism, bi-directionally rotating at variable speeds

**Iris:** 5~100% linearly adjustable with Macro

**Focus:** DMX controlled focus

**Dimmer:** 0~100% linearly adjustable

**Shutter:** Electronic strobe, 0.3~20 F.P.S

### Control and Programming:

**Control:** DMX512, 3-pin and 5-pin interfaces

**Channels:** Short Mode: 14, Standard Mode: 19, Extended Mode: 23

Master/slave mode, Stand-alone mode, Self-test mode

1582 Xingye Avenue, Nancun, Panyu, Guangzhou, 511442, China  
+86-20-3995 2379 Fax.: +86-20-3995 2330 [www.pr-lighting.com](http://www.pr-lighting.com)

**Head Movement:**

Pan 540° or endless, Tilt 270° with auto position correction  
Swap and Invert functions of Pan and Tilt

**Physical Features:**

**Housing:** Composite plastic, IP20

**Weight:** 17.5Kg

**Other Functions:**

Adjustable Pan & Tilt speed  
Fixture usage time display  
Software version display  
DMX512 Wireless Function  
Optional DMX512 wireless Transmitter

**Package Dimensions:**

**Standard:** 560x530x640(mm)

**Packed Quantity:** 1PC/Carton

**Size(mm):** ( L: 339mm W: 411mm H: 581mm (head in vertical direction))

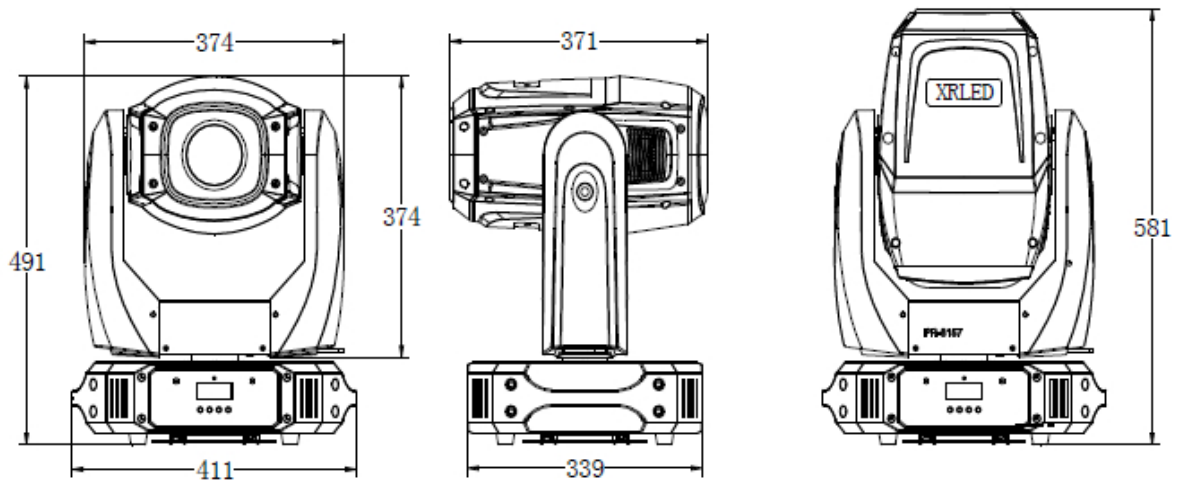

1582 Xingye Avenue, Nancun, Panyu, Guangzhou, 511442, China  
+86-20-3995 2379 Fax.: +86-20-3995 2330 [www.pr-lighting.com](http://www.pr-lighting.com)

**Light Output:**

